

Largo Prenda

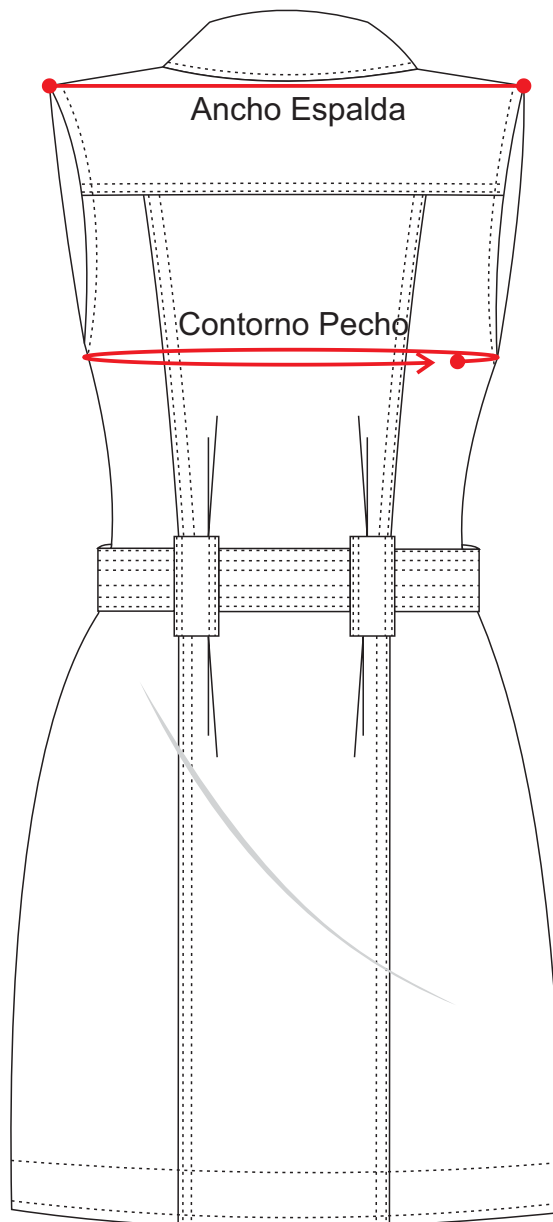
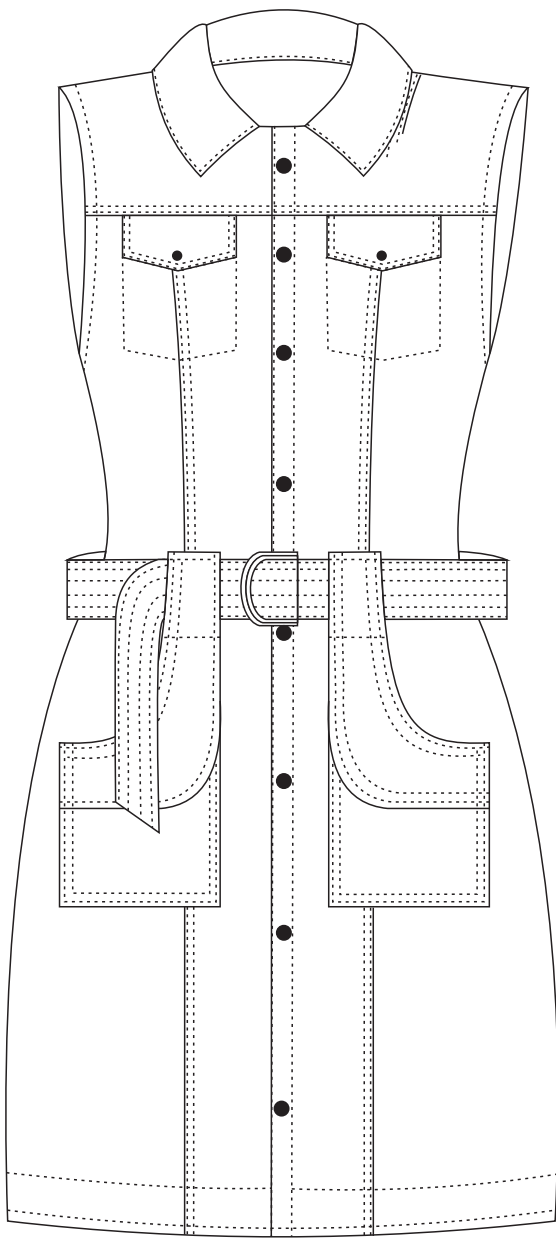

GUIA DE TALLAS

| Talla | Largo de prenda | Contorno Pecho | Ancho Espalda |
|-------|-----------------|----------------|---------------|
| S | 80 cm | 88 cm | 41 cm |
| M | 82 cm | 93 cm | 42 cm |
| L | 84 cm | 98 cm | 43 cm |